

HOLD FAST

Rigging System

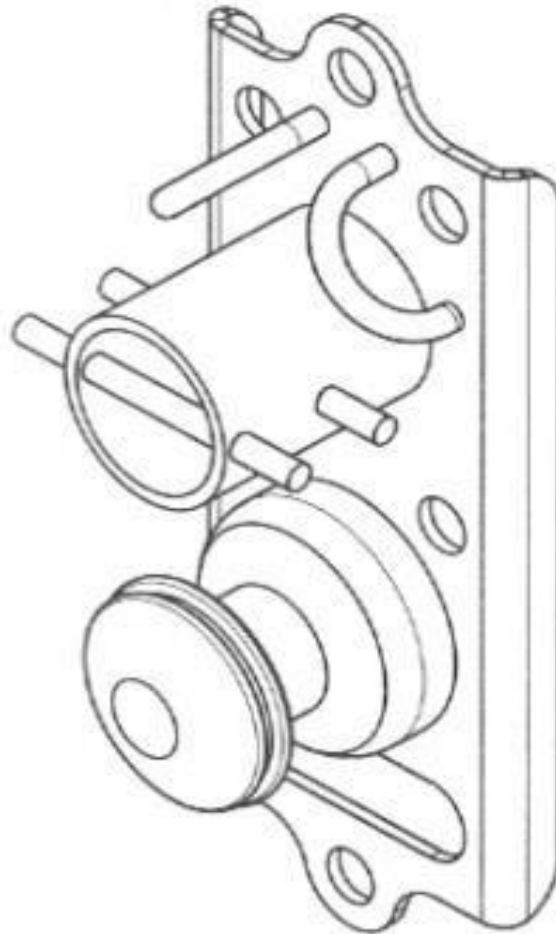

Safety & Operating Instructions

OG & XL Models

Rope Management Solutions, LLC

Thorntown, IN 46071 | 317-435-0392

contactus@ropemanagementsolutions.com | holdfast-rigging.com

Patent Pending · 5:1+ Safety Factor · ANSI Z133 · Designed, Built & Field Tested in the USA

CONTENTS

Section	Page
Warnings & Safety Precautions	3
Product Identification & WLL Ratings	4
Compliance & Safety Rating	4
Product Life	5
Package Contents & Parts Identification	5-6
Harken Radial Self-Tailing Winch	7-8
Winch Precautions, Cleaning & Lubrication	8-9
Exploded View Diagram of Winch	10
Stem Mounting Instructions	11
Horizontal Anchoring Method	12
Rope Routing Instructions	13
Rigging Work Zone	14
Rope Routing – Self-Tailing Winch	14-15
Rope Routing -Double Working Lines	16
Accessory Carabiner Port, Bollard Care	17
QR-Code and Support	17

WARNINGS & SAFETY PRECAUTIONS

CRITICAL WARNING

Activities using this equipment are inherently dangerous. It is not possible to cover every eventuality relating to the use of this equipment. Purchasers and users of the HOLD FAST rigging device should seek professional training from a fully qualified and competent instructor prior to engaging in any activity. If you are not able, or not in a position to assume this responsibility, **DO NOT** use this product. The manufacturer, its distributors, and retailers do not accept any liability if users do not follow the instructions correctly. Only the techniques shown in the diagrams are authorized. Any other use deviating from those shown may result in serious injury or death.

Prior to each use a complete on-site risk assessment must be carried out to ascertain that the device is appropriate to the work being undertaken. The HOLD FAST rigging device must also be compatible with all other components within the rigging system.

Users must always ensure that all components of the rigging system are suitable for the foreseeable loadings that may be applied during use. Poor technique and shock loading may cause catastrophic failure of this equipment and should be avoided. Where a failure of the product may occur, a suitable backup system must be installed and used. All components must be inspected before and after each lowering/lifting operation. Retire the HOLD FAST from use if there are any tactile or visual signs of wear or damage.

The HOLD FAST rigging device must always be used with the correct diameter of rope. You must never exceed the recommended maximum diameters. Each device has a Working Load Limit (WLL) — this is the maximum load allowed to be applied to the device either for lifting or lowering, above which catastrophic failure will occur. You should never exceed the lowest rated section or component within any rigging system.

Safety Rules

- The HOLD FAST rigging device must **NEVER** be used for lifting or lowering people. Neither the self-tailing winch nor the rigging bollard are intended or rated for use as Personal Protective Equipment (PPE).
- Always keep body parts, loose clothing, and debris away from the device when in use.
- Always use appropriate hand, head, and eye protection when operating the device.
- When holding the working line, **NEVER** wrap the line around your hands or other body parts. Always ensure it can run freely in case you need to release the line in an emergency.
- Do not stand at any time, or allow others to stand, directly under the load being lowered or under the work being performed above. Ensure all persons are operating from a safe distance.
- Any potential dynamic/shock loading must always be kept to an absolute minimum.
- All connecting devices or components must be retired from use if subjected to impact loading.
- To avoid damage to the device, minimize negative rigging fall distance within the system as much as possible.
- Always maintain control of each and every suspended load until it has safely reached the ground and has been untied.
- All moving parts must be lubricated regularly using suitable lubrication. Ensure no excess lubrication contacts any textile accessories or working line. Remove all excess lubrication immediately.
- Products covered under these instructions should never be resold or used by a third party after use by the original purchaser.

We recommend that all users of this equipment be given a copy of these instructions. They must read them, understand them, and explicitly follow all instructions and cautions. Any person using this equipment should be fully trained and competent in its use before carrying out any rigging operations.

PRODUCT IDENTIFICATION & WLL RATINGS

Identification Markings

Each HOLD FAST rigging device contains a product identification number located on the back of each rigging plate. It is a multiple-digit number indicating the year of manufacture and corresponding unit number (e.g., 23001). Use this number when communicating with the manufacturer regarding your product.

Working Load Limit (WLL) Ratings

The HOLD FAST rigging device must always be used with the correct diameter of rope. You must **never** exceed the recommended maximum rope diameters. Each device component has a Working Load Limit (WLL) — the maximum load allowed to be applied to the device either for lifting via self-tailing winch or lowering on the fixed bollard. These values are based on a static vertical load applied as specified in these instructions.

NOTE

Dynamic loads can multiply the forces in a rigging system. A dynamic load weighing considerably less than the WLL can still exceed the limit due to forces caused by its drop into the system. ALL potential loads — static and dynamic — should be carefully calculated and dynamic loads minimized where possible.

Each device is fitted with a max rope diameter and WLL capacity label as shown below:

Model / Component	Max Rope Diameter	Working Load Limit (WLL)
HOLD FAST OG — Bollard	9/16"	2,000 lbs
HOLD FAST XL — Bollard	5/8"	2,500 lbs
Harken Radial 20 ST Winch (OG)	1/2"	950 lbs
Harken Radial 40 ST Winch (XL)	1/2"	1,500 lbs

⚠ WARNING

You must ascertain that the device chosen is appropriate to the work being undertaken. The WLL is based on using a sufficiently rated anchor sling attached to the designated anchor point(s). The anchor sling is the primary load-bearing attachment. The ratchet strap is designed for vertical positioning **ONLY** and should **NEVER** be used alone as a mounting strategy.

COMPLIANCE & SAFETY RATING

The HOLD FAST Rigging System is **rated at a 5:1+ safety factor**. This product is intended for use in accordance with **ANSI Z133 safety practices** for arborist operations. Users and operators should be trained and certified in accordance with applicable ANSI Z133 requirements.

PRODUCT LIFE

If the product shows tactile or visual signs of wear, has come into contact with caustic chemical agents, experienced abrasion causing deformation of any component, or has been crushed or bent in any way, it must be retired from use immediately.

The following maximum product life specifications are for guidance purposes only:

Daily Use	Weekly Use	Occasional Use
Maximum 2 years	Maximum 3 years	Maximum 5 years

The total maximum life of this product (storage before use + lifetime in use) is limited to 10 years. In good storage conditions this product may be kept for as many as 5 years before the first use without affecting its future duration in use.

PACKAGE CONTENTS

Your HOLD FAST rigging system will include the following items (assembly included):

Hold Fast OG	Hold Fast XL
1. Rigging plate / bollard	Rigging plate / bollard
2. Harken Radial 20 ST Winch	Harken Radial 40 ST Winch
3. 1 Ratchet strap (3,000 lbs WLL)	2 Ratchet straps (3,000 lbs WLL each)
4. Winch handle	Winch handle
5. Anchor Sling 16 Strand 16ft	Anchor Sling 5/8" 18ft
6. Instruction Manual	Safety & Operating Instructions

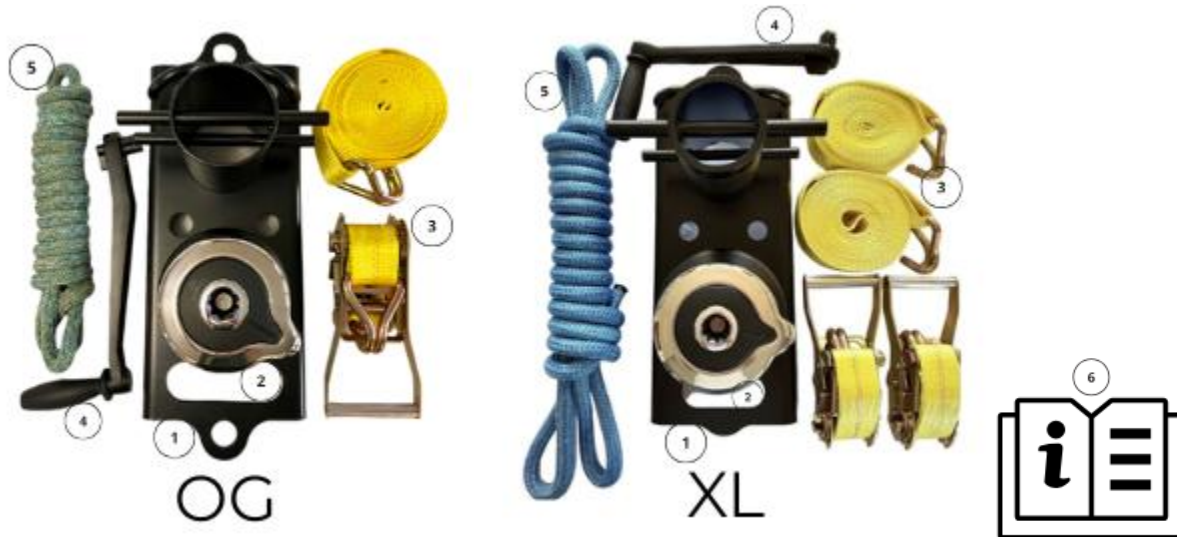

PARTS IDENTIFICATION

Identifying Parts of the HOLD FAST Rigging Device

#	Component	Notes
1	Rigging Plate	Main structural plate
2	Rigging Bollard	2a: front post 2b: rear post
3	Fairleads	3a: bollard fairlead 3b: winch fairlead
4	Harken Radial Self-Tailing Winch	OG: Radial 20 XL: Radial 40
5	Hand Port	Carrying handle for OG and Primary anchor attachment point for XL-For 5/8" anchor sling
6	Basal Anchor Port OG	*Omitted on XL*
7	Ratchet Strap Anchor Ports	7a and 7b, and additional 5 for XL
8	Additional Accessory Ports	8a and 8b
9	Accessory Carabiner Port	For approved rigging accessories

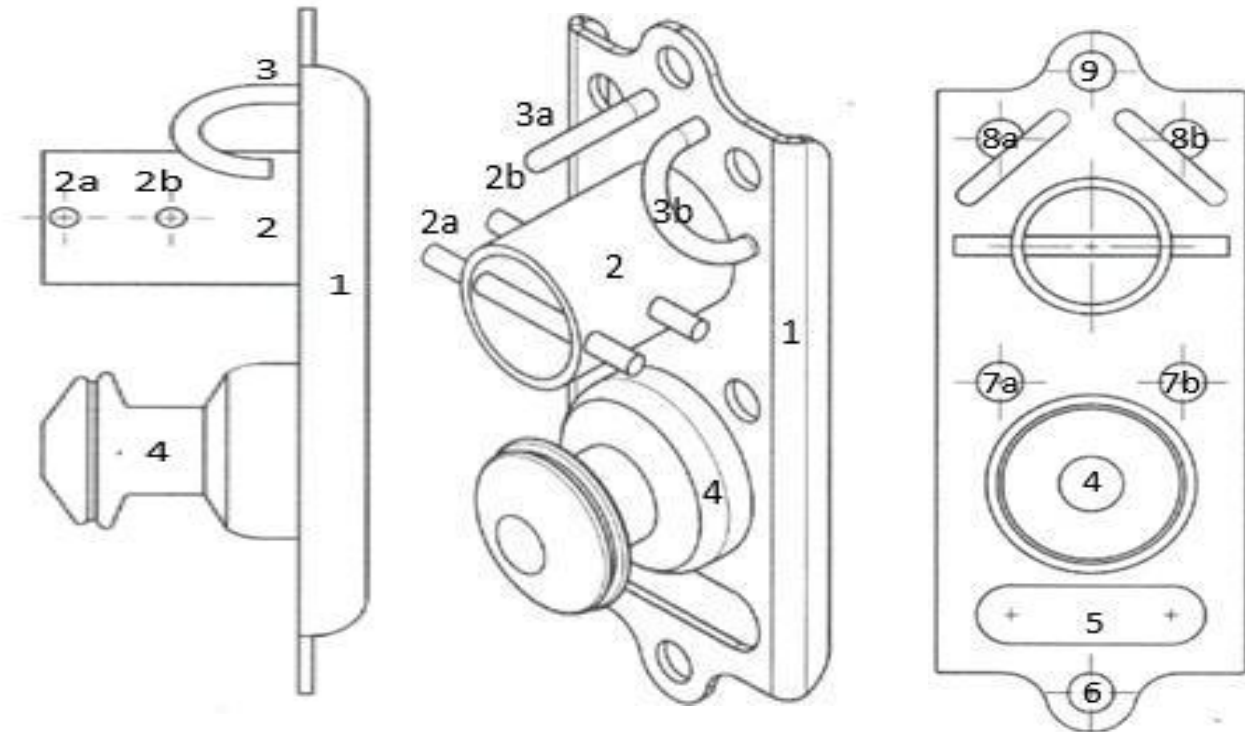

HARKEN RADIAL SELF-TAILING WINCH

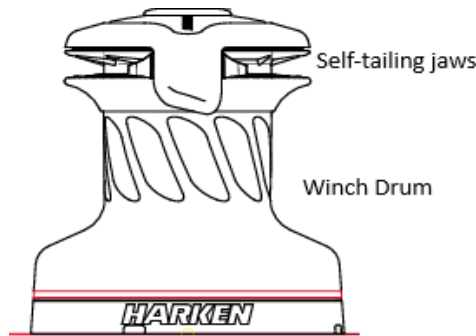

Technical Characteristics

Model	Speed	Power Ratio
Hold Fast OG	1-Speed (Radial 20)	19.2:1
Hold Fast XL	2-Speed (Radial 40)	13.5:1 & 39.9:1

Maximum Working Load Limits

The Hold Fast working load limits have been independently established. The following values represent the maximum loads rated for these systems:

Winch Model	Working Load Limit (WLL)
Harken Radial 20 ST (Hold Fast OG)	950 lbs
Harken Radial 40 ST (Hold Fast XL)	1,500 lbs

⚠ WARNING

The maximum working load (MWL) for the **20 ST Radial Winch** is **1213 lbs. (550 Kg)**, and the (MWL) for the **40 ST Radial Winch** is **1874 lbs. (850 Kg)**. Subjecting the winch to loads above the WLL can cause the winch to fail suddenly and unexpectedly during high-load events, causing severe injury or death.

Compatible Winch Line Diameters

Harken Radial self-tailing winches have jaws preloaded with springs that adapt automatically to the following line diameters:

Minimum Rope Diameter	Maximum Rope Diameter
6 mm (1/4")	12.7 mm (1/2")

⚠ WARNING

Use only line of a diameter between the limits listed above. DO NOT use wire rope, chain, or line not approved for arboriculture/marine use. To avoid accidents, carefully read, understand, and follow all warnings and instructions in the Harken Catalogue at www.harken.com.

Winch Precautions, Cleaning & Lubrication

Operating Precautions

⚠ WARNING

Using the winch demands important precautions: Do not use Harken winches if you are not sufficiently trained and experienced in the general use of self-tailing winches.

- Keep your fingers, hands, loose clothing, gloves, and tools away from moving parts. In particular, avoid them entering between the line and the winch.
- Before using the winch, ensure all people and objects are clear of the movement of the reacting components of the system.
- Take particular care when releasing the line under load.
- If the winch is not in use, remove the handle and place it in a safe location outside the work zone.
- Do not apply a load greater than the maximum working load of the winch.
- Winches must be visually inspected at the beginning and end of each use.
- Winches must be completely overhauled, cleaned, and lubricated at least every 6 months. After inspection, replace any worn or damaged components. Refer to the Harken Radial Winch Maintenance Manual.
- **WARNING!** Periodic maintenance must be carried out on a regular basis. Lack of adequate maintenance shortens the life of the winch.

Basic Cleaning Instructions

For assembly and disassembly, refer to the Harken Radial Winch Maintenance Manual.

- Wash winches frequently with fresh water, always after each use.
- **WARNING!** Use a soft cloth for all cleaning and polishing operations. Do not use abrasive cloths on any component.
- Clean the bronze components and the anodized aluminum drums with a solution of water and vinegar (1 part vinegar + 2 parts water).
- Ensure the holes and drainage channels in the base of the winch are not obstructed so that water and debris does not collect.

Basic Inspection & Lubrication

For assembly and disassembly, refer to the Harken Radial Winch Maintenance Manual.

- Once the winch is completely disassembled, clean the parts with a degreasing agent that does not leave residues and is appropriate for metal components. Rinse plastic parts in fresh water.
- Dry all parts with lint-free cloths.
- Inspect gears, bearings, pins, and pawls for any signs of wear or corrosion.
- Carefully check the teeth of gears and ring gears to ensure there are no traces of wear.
- Check roller bearings to ensure there are no breaks in the bearing cages.
- Use a brush to lightly lubricate all gears, gear pins, teeth, and all moving parts with **grease**. Lightly lubricate pawls and springs with **oil only**. **DO NOT use grease on the pawls!**

EXPLODED VIEW DIAGRAM

NOTE

Exploded view with recommended maintenance products. Refer to the Harken Radial Winch Maintenance Manual for additional instructions and parts guide.

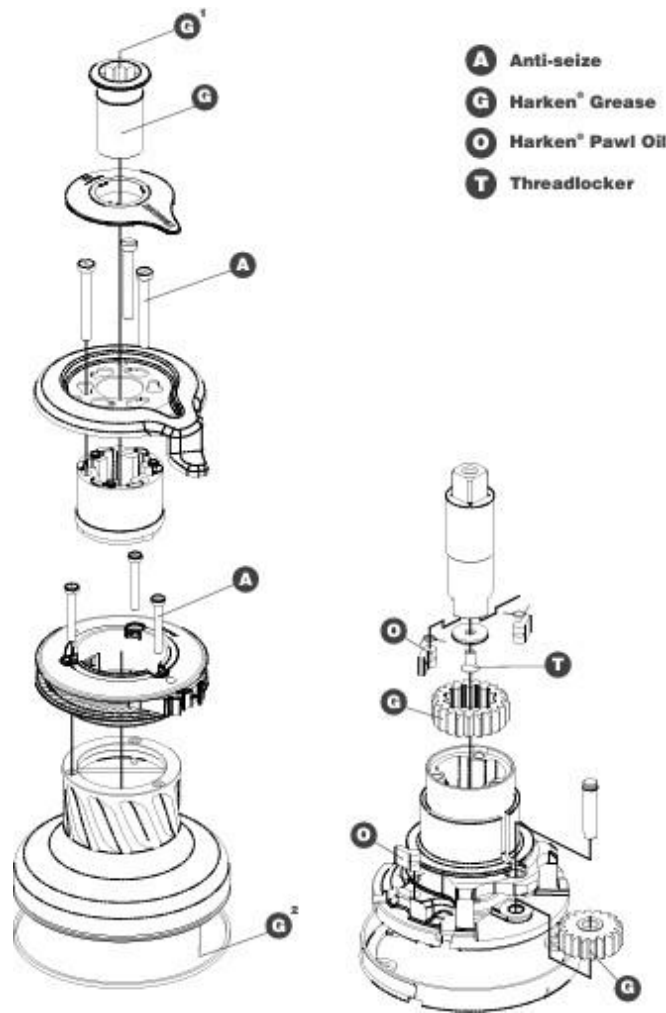

STEM MOUNTING INSTRUCTIONS

⚠ WARNING

The WLL is based on using a sufficiently rated anchor sling attached to the designated anchor point(s). The ratchet strap is designed for vertical positioning **ONLY** and should **NEVER** be used alone as a mounting strategy.

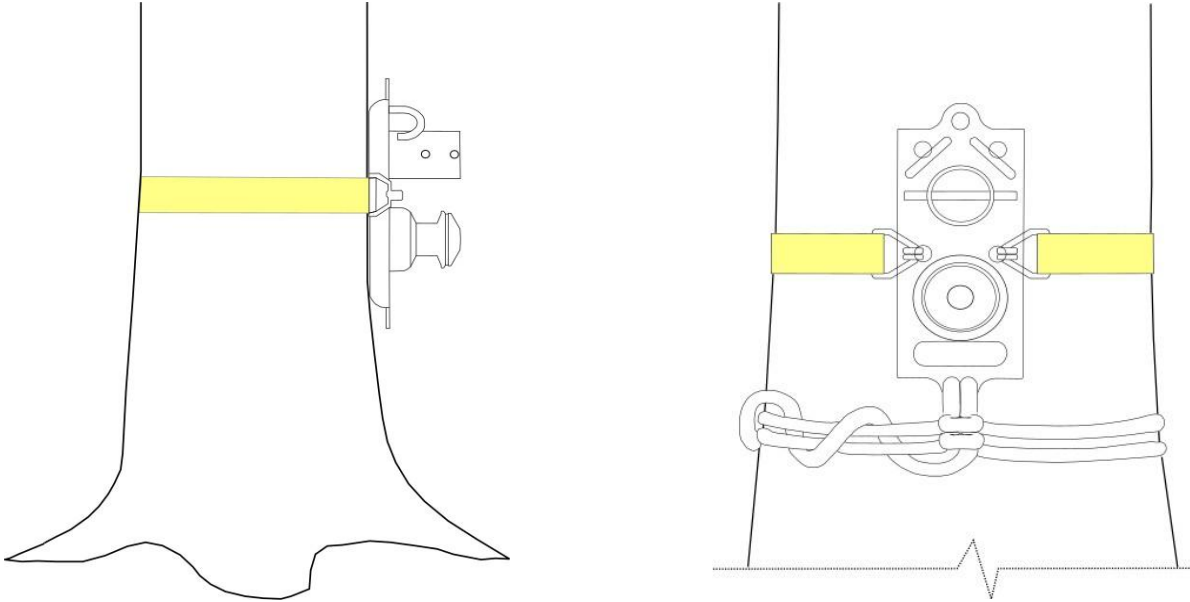

ENSURE THE WORK AREA IS FREE AND CLEAR OF ANY OBSTACLES AND A FULL TREE RISK ASSESSMENT HAS BEEN UNDERTAKEN BEFORE MOUNTING THE HOLD FAST RIGGING SYSTEM.

- When selecting the mounting location, choose an area where there is little or no stem taper. If the tree is to be removed, this can be achieved by shaping the stem prior to mounting.
- **Never** mount around the base/root flare of the tree — this can result in vertical slippage when load is applied.
- Install ratchet strap around the stem of the tree (Step 1) and terminate the hooked end in anchor ports (7a, 7b). A second ratchet strap can be installed in anchor ports (8a, 8b) if desired. Ensure hooks are facing toward the tree, fed correctly through the ratchet handle. Tighten the ratchet system as snugly as possible.
- Once securely mounted, attach an appropriately rated anchor sling (Step 2) to either the Basal Anchor Port (6) for up to 9/16" diameter line, or through the Hand Port (5) for XL, or if using a larger diameter sling.
- Ensure the sling is of sufficient length to terminate the hitch properly.

⚠ CRITICAL WARNING

NEVER USE THIS DEVICE WITHOUT THE ANCHOR SLING ATTACHED. The anchor sling is the primary load-bearing attachment for the system.

HORIZONTAL ANCHORING METHOD

The HOLD FAST rigging system is unique in that it can be rigged in the horizontal position.



ENSURE THE WORK AREA IS FREE AND CLEAR OF ANY OBSTACLES AND A FULL TREE RISK ASSESSMENT HAS BEEN UNDERTAKEN BEFORE MOUNTING THE HOLD FAST RIGGING SYSTEM.

Mounting Instructions:

- For horizontal anchoring to be successful, you must have at least 2 anchors positioned approximately 45 degrees from the Basal Anchor Port (6). This allows for a triangular force to be applied to the rigging system when brought under load.
- Run a rated sling/rigging line from an appropriately rated anchor through the Hand Port (5), under the rigging plate, up through Anchor Port (7a), across the top of the rigging plate, and down through Anchor Port (7b), again running the line behind the rigging plate to emerge out of the Hand Port (5). Terminate the end of the sling/line at the second anchor.
- Run the rigging line through the fairlead and feed line clockwise around the self-tailing winch drum.
- Rotate the winch handle counter-clockwise to tension the rigging line.
- Tension the rigging line to desired tension.

NOTE

The wider your anchoring positions are in relation to the Basal Anchor Port (6),(5) for XL, the more stable your horizontal rigging platform will be.

ROPE ROUTING INSTRUCTIONS

⚠ WARNING

The following instructions demonstrate the correct routing of the working line(s) for the HOLD FAST rigging system. Never use alternative routing — this may result in injury or death.

The HOLD FAST rigging system allows for the use of multiple working lines simultaneously.

The HOLD FAST rigging device must always be used with the correct diameter of rope. You must never exceed the recommended maximum rope diameters. Each device component has a Working Load Limit (WLL) – This is the maximum load allowed to be applied to the device component either for lifting with the self-tailing winch or lowering on the fixed bollard. These values are based on a static vertical load being applied and used as specified in these instructions. However, a dynamic load can multiply the forces incurred on a rigging system; a dynamic load weighing considerably less than the WLL of the device can still exceed the limit due to the multiplied forces caused by its drop into the system. Therefore, ALL potential loads (static and dynamic) should be carefully calculated and dynamic loads minimized where possible.

Rope Routing to Bollard

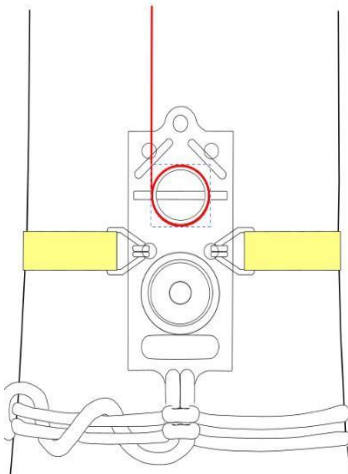

1. Ensure the working line enters *beneath* the rigging bollard fairlead (3a or 3b) from a vertical point directly above the device.
2. If NOT utilizing the winch, the working line can enter beneath either bollard fairlead (3a or 3b).
3. Pass the rope behind the rear bollard post (2b).
4. Pull the rope tight and continue with further wraps between the rear (2b) and front (2a) bollard posts.
5. Apply the appropriate number of wraps around the bollard (2), based on the size/weight of the load being lowered.
6. To suspend/lock off a load: wrap the working line a minimum of 4 times around the bollard and finish by applying a cleat hitch on the front bollard post (2a).

⚠ WARNING

Once you are in a position to commence lowering, stand clear of the drop zone, ensuring the working line will not be obstructed by the load being lowered.

Rigging Working Zone — KEEP CLEAR

- **ALWAYS** keep body parts, loose clothing, and debris away from the device when in use.
- **ALWAYS** remain outside of the Bollard Working Zone — the zone in which all lines feed through fairleads, bollards, and winch while in operation.
- **ALWAYS** maintain working line load pressure on bollard posts while engaged in lowering operations. This allows the user to remain at a safe distance from the device while lowering rigged pieces.

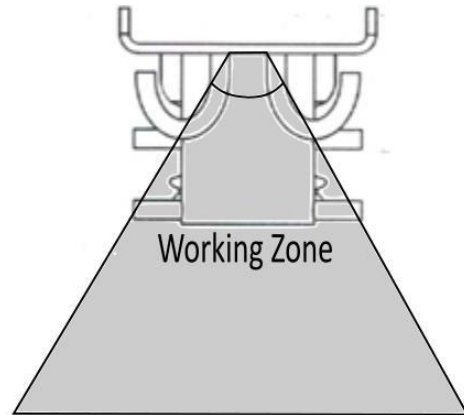
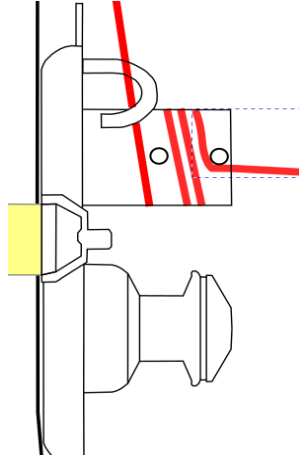

⚠ WARNING

Position yourself, body parts, loose clothing, and loose hair **OUTSIDE** the Rigging Working Zone at all times. Doing so also ensures correct rope alignment, greatly reducing the chance of wraps **overlapping** or **unspooling** during lowering operations. Uncontrolled falling loads can cause extreme injury or death. Any person using this equipment should be fully trained and competent in its use **before** carrying out **any** rigging operations.

Rope Routing to Self-Tailing Winch

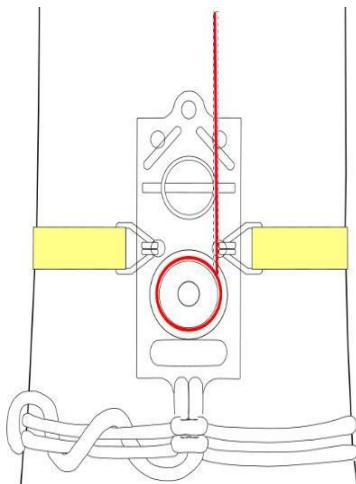

1. Ensure the working line enters beneath the rigging bollard fairlead (3b) from a vertical point directly above the device.
2. Pass the rope behind the rear bollard post (2b) and toward the winch (4) positioned below the bollard.
3. Take at least **3 turns** (clockwise) around the winch drum (4) in the direction the winch rotates. For high loads, take an additional turn.
4. Pull rope taught. To ensure correct functioning of the self-tailing mechanism, the number of turns taken around the drum must **NOT** hamper the movement of the lower self-tailing jaw.

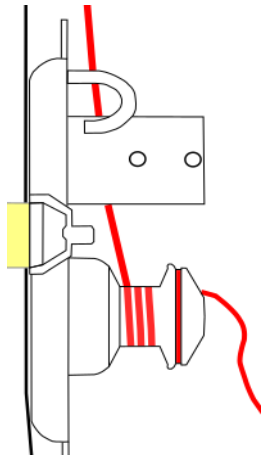

5. The more turns taken around the winch drum (4), the lower the load the operator has to handle.
6. **DO NOT** take turns around the base of the winch drum.
7. Position the working line over the self-tailing arm and take another turn positioning the line in the self-tailing jaws. The jaws will automatically adjust to the size of line being used. Harken recommends 1/4"-1/2" line for the Radial winch. Do not exceed the recommended diameter for optimal self-tailing performance.
8. At this point the working line is locked off.
9. Insert the winch handle into the head of the winch. Begin tensioning the working line by rotating the handle **counter-clockwise**.
10. **Take particular care while releasing the line under load!**

⚠ CRITICAL WARNING

DO NOT STAND UNDER THE LOAD AT ANY TIME DURING RIGGING OPERATIONS.

Removing Line from Self-Tailing Jaws

1. To remove wraps: place the palm of your hand carefully on the winch drum to maintain rope/drum pressure and carefully remove one turn at a time until the load begins to move freely on the winch drum. Be particularly mindful of keeping fingers clear of line wraps and the winch drum.
2. Before lowering the load, **maintain control over the load from a distance** by capturing the line on the bollard. Take a half turn around the forward bollard post (2a) and position yourself outside of the Working Zone. This ensures you remain clear of pieces under load and maintains correct rope alignment on the winch drum as wraps move freely when tension is released.

⚠ WARNING

Position yourself, body parts, loose clothing, and loose hair OUTSIDE the Rigging Working Zone. Uncontrolled falling loads can cause extreme injury or death. Any person using this equipment should be fully trained and competent in its use before carrying out any rigging operations.

Maintaining control over a load from a by capturing the working line with a half turn around the front bollard post (2a)

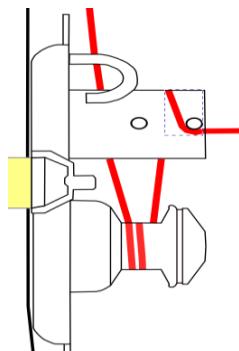

Rope Routing — Double Working Lines

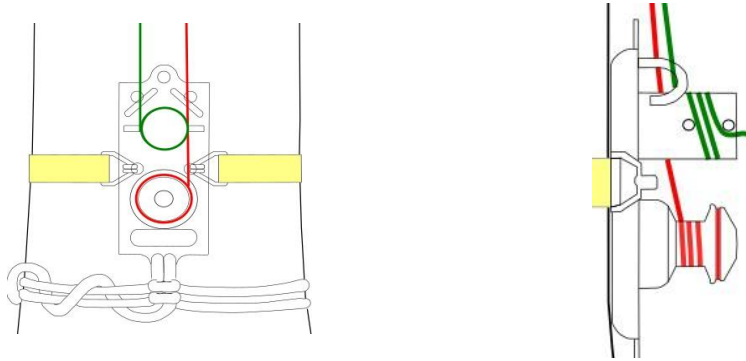

1. Ensure working lines enter beneath the rigging bollard fairleads (3a, 3b) from a vertical point directly above the device.
2. Pass the line intended for the bollard through bollard fairlead (3a). Pass the line intended for the self-tailing winch through fairlead (3b).
3. Pass the bollard line (Green line in diagram above) **between** the front and rear bollard posts — this ensures available space for the self-tailing line (Red line in diagram above) behind the rear bollard post. Continue with the Bollard Routing instructions to complete the correct routing and operation sequence.
4. Pass the winch line (Red line in diagram above) **behind** the rear bollard post (2b). Continue with the Self-Tailing Winch Routing instructions to complete the correct routing and operation sequence.

⚠ WARNING

It is important while operating multiple lines to maintain separation between the bollard working line and the self-tailing winch working line. Line isolation is especially important while the rigging system is under load. Damage to both working lines will occur if care is not taken to ensure proper line routing through the system. Before applying any load to either line ensure that both working lines are appropriately isolated in the rigging system. Damaged working lines can lead to unexpected failure of one or both load bearing lines. Uncontrolled falling loads can cause extreme injury or death.

⚠ WARNING

The user should position self, body parts, loose clothing, loose hair, etc. **OUTSIDE** of the Rigging Working Zone. By positioning oneself outside of this zone it also ensures correct rope alignment, greatly reducing the chance for wraps **overlapping** or **unspooling** during lowering operations contributing to the uncontrolled descent of the load. Uncontrolled falling loads can cause extreme injury or death. **Any person using this equipment should be fully trained and competent in its use before carrying out any rigging operations.**

ACCESSORIES, BOLLARD CARE & SUPPORT

Accessory Carabiner Port (9)

The HOLD FAST rigging plate allows space for the quick addition of rigging accessories to the system. For a list of approved accessory tools, please contact the manufacturer or visit holdfast-rigging.com.

Bollard Care

Your HOLD FAST Rigging System is fully powder coated except for a 3" strip between the two horizontal bollard posts. This is to ensure that your ropes remain free from melting to the bollard during high-friction rigging scenarios. The exposed metal has been acid washed, gun blued, and sealed to resist corrosion.

A simple application of gun bluing agent and/or a light oiling is all that is needed to maintain a sleek, gun barrel appearance.

NOTE

To protect the finish during shipping, the exposed section has been lightly coated with oil and wrapped in plastic. Before first use, simply wipe off any excess oil from the exposed metal surface.

QR Code — Setup, Manual & Training Videos

A scannable QR code is included with every HOLD FAST unit. Scan the code to access:

1. Setup instructions
2. Complete operator manual
3. Training videos from the Hold Fast Learning Center

These resources are also available at holdfast-rigging.com.



Rope Management Solutions, LLC | Thorntown, IN 46071 | 317-435-0392

contactus@ropemanagementsolutions.com | holdfast-rigging.com

Patent Pending · 5:1+ Safety Factor · ANSI Z133 · Hold Fast Rigging System © Rope Management Solutions, LLC

We recommend that all users of this equipment be given a copy of these instructions. They must read them, understand them, and explicitly follow all instructions and cautions. Any person using this equipment should be fully trained and competent in its use before carrying out any rigging operations.